

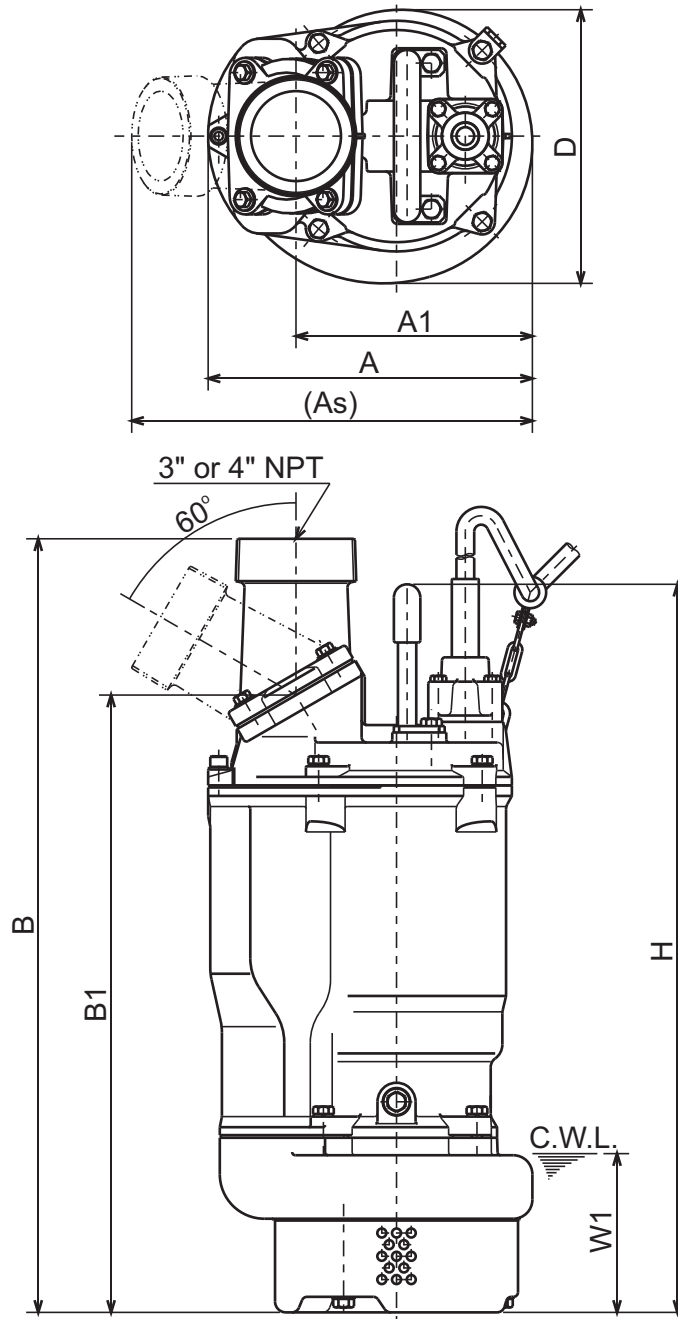

**KTZ - SERIES
DEWATERING PUMPS**

DIMENSIONS

**KTZ35.5-63
KTZ45.5-63**



C.W.L. : Continuous running Water Level

DIMENSIONS:USCS (Inch)

Model	HP	NOM. SIZE	Pump & Motor								C.W.L.	Wt. (lbs.)
			A	As	A1	B	B1	D	H	W1		
KTZ35.5-63	7.5	3"	12 1/16	14 5/16	8 13/16	28 3/8	22 15/16	10 3/16	27 1/16	5 7/8	167	
KTZ45.5-63	7.5	4"	12 1/16	14 7/8	8 13/16	28 3/4	22 15/16	10 3/16	27 1/16	5 7/8	170	

DIMENSIONS:METRIC (mm)

Model	kW	NOM. SIZE	Pump & Motor								C.W.L.	Wt. (kg)
			A	As	A1	B	B1	D	H	W1		
KTZ35.5-63	5.5	80	306	363	223	721	583	259	688	150	76	
KTZ45.5-63	5.5	100	306	379	223	731	583	259	688	150	77	



KTZ - SERIES DEWATERING PUMPS

PERFORMANCE CURVE

MODEL	BORE	HP	KW	RPM	SOLIDS DIA	LIQUID	SG.	VISCOSITY	TEMP.
KTZ35.5-63	3"/80mm	7.5	5.5	3545	0.334"/8.5mm	Water	1.0	1.123 cSt.	60°F
PUMP TYPE	PHASE	VOLTAGE	AMPERAGE		HZ	STARTING METHOD	INS. CLASS		
Dewatering Pump	3	208-230/460/575	21.0-19.7 / 10.0 / 7.9		60	Direct On Line	F		
CURVE No.	DATE	PHASE	VOLTAGE	AMPERAGE	HZ	STARTING METHOD	INS. CLASS		
-	-	-	-	-	-	-	-		

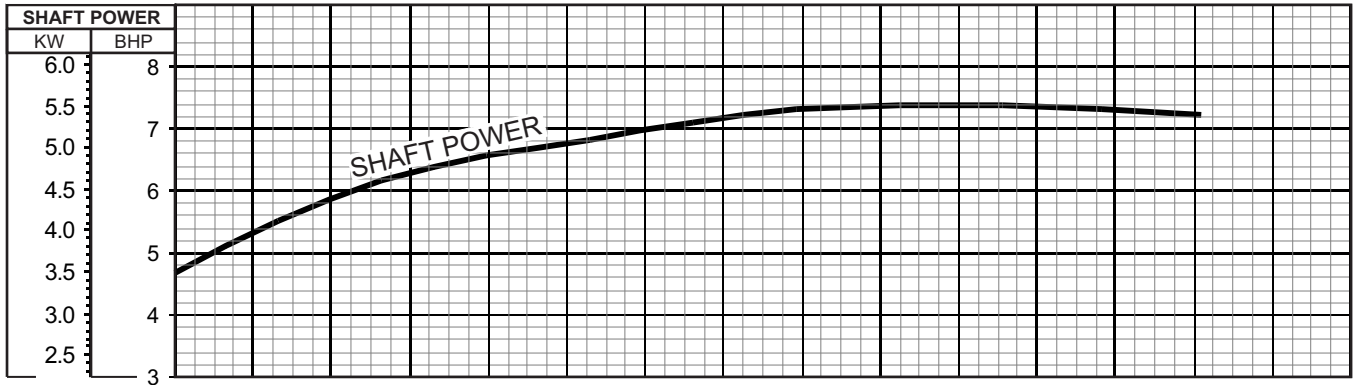
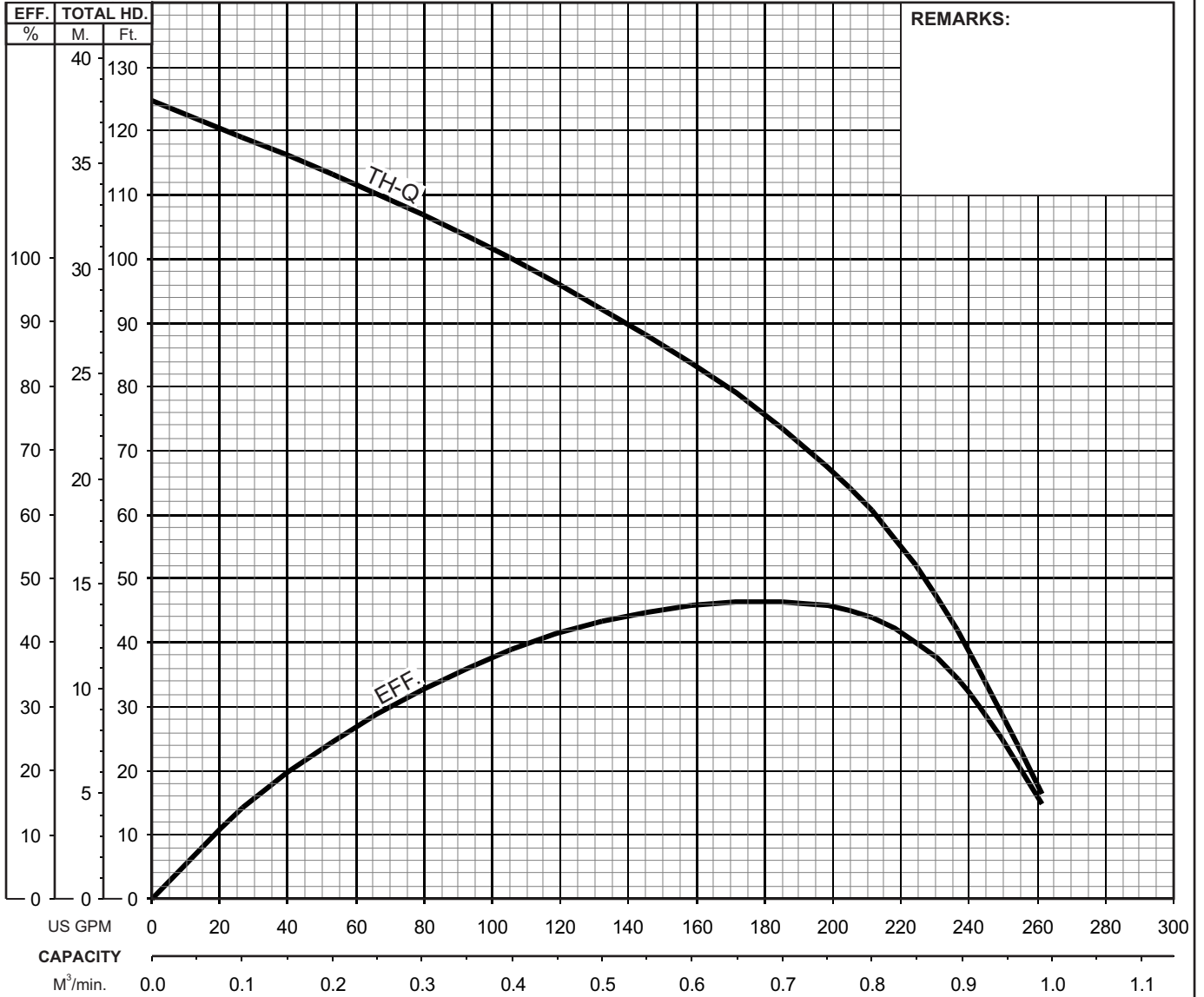

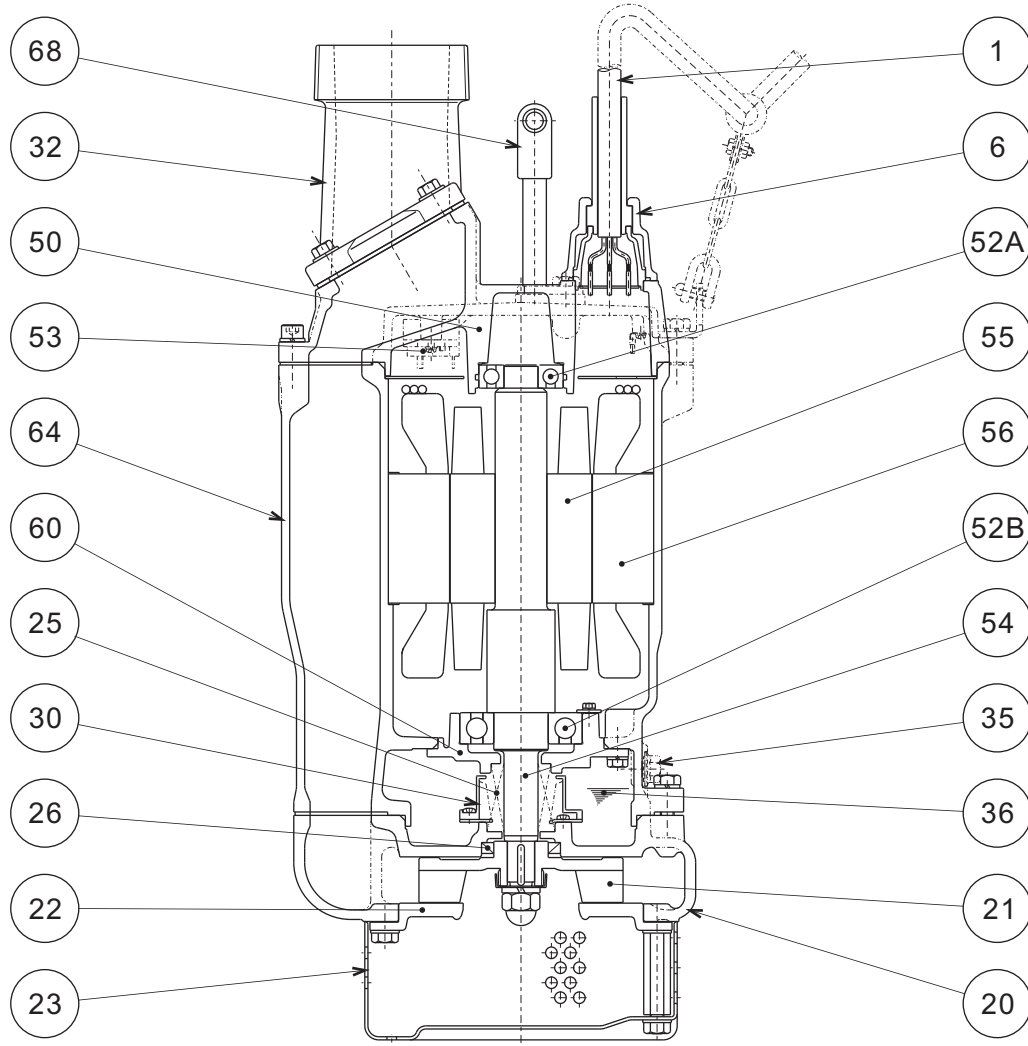
**TSURUMI PUMP**
**KTZ - SERIES
DEWATERING PUMPS**
SECTIONAL VIEW
**KTZ35.5-63
KTZ45.5-63**

ITEM#	DESCRIPTION	MAIN MATERIAL / NOTE	RELATED ASTM, AISI CODE	RELATED EN CODE	Q'TY
1	Power Cable	Chloroprene Sheath AWG12/4-50ft			1
6	Stuffing Box	Cast Iron	A48M Class30B	EN 1561 GJL-200	1
20	Pump Casing	Cast Iron	A48M Class30B	EN 1561 GJL-200	1
21	Impeller	High Chrome Cast Iron	A532 Class III Type A	DIN 1695 G-X260Cr27	1
22	Suction Cover	Ductile Cast Iron	A536 80-55-06	EN 1563 GJS-500-7	1
23	Suction Strainer	Steel (Cold Rolled)	A109/A1008	EN 10130	1
25	Mechanical Seal	Silicon Carbide / H-25T			1
26	Oil Seal	Nitrile Butadiene Rubber / TC-40588			1
30	Oil Lifter	PBT Resin			1
32	Discharge Connection	Cast Iron / NPT 3" or 4"	A48M Class30B	EN 1561 GJL-200	1
35	Oil Plug	Stainless Steel	S 30400	1.4301	1
36	Lubricant	Turbine Oil ISO VG32 or SAE10W-20			
50	Motor Head Cover	Cast Iron	A48M Class30B	EN 1561 GJL-200	1
52A	Upper Bearing	#6305ZC3			1
52B	Lower Bearing	#6308ZC3			1
53	Motor Protector				1
54	Shaft	Stainless Steel	S 42000	1.4028	1
55	Rotor				1
56	Stator				1
60	Bearing Housing	Cast Iron	A48M Class25B	EN 1561 GJL-150	1
64	Motor Housing	Cast Iron	A48M Class25B	EN 1561 GJL-150	1
68	Handle	Carbon Steel Pipe + NBR Rubber	A53 Type F	DIN 1615 St33	1

PARTS LIST		HI HEAD DEWATERING PUMP			6/7/2018	
ITEM	PART No.	DESCRIPTION	QTY	SIZE	MATERIAL	NOTES
1	140-074-15	Hex.Bolt	3	M10x20	SUS304	
2	068-000-36	Handle	1	KTZ23.7/45.5	SGP+SS	
3	010-121-19	Cable Clip Rubber	1	No.1	NBR	
4	010-120-18	Cable Clip	1	No.2-1	SPC	
5	140-032-37	Hex.Bolt	1	M6x15	SWRM	
6	141-004-59	Hex.Nut	1	M6	SWRM	
7	095-131-18	Chain	1	4mm(3L)	SS	
8	011-110-11	Shackle	1	6mm(M8,SC)	SS	
9	001-841-33	Cabtyre Cable Set (50') 60Hz(USA)	1	2PNCTF4Cx3.5mm2	KTZ	
10	140-060-18	Hex.Bolt	4	M8x50	SUS304	
11	006-167-17	Stuffing Box	1	No.1-3	FC	
12	122-121-12	O-Ring	1	G-50(49.4xd3.1)	NBR	*
13	004-168-12	Cable Bush 60Hz(USA)	1	No.2	CR	
14	008-156-19	Mould Cover	1	No.1-3	ADC	
15	009-123-10	Terminal	4	P-5.5	CU	
16	009-101-12	Terminal(C/W Screw)	4	d12x(d6.6xd6.6)x25l	C3604	
17	009-123-10	Terminal	4	P-5.5	CU	
18	002-135-14	Heat Shrink Tube (Sold per meter)	m	A(d15x0.3t)	(V/m)	
19	002-132-11	Heat Shrink Tube (Sold per meter)	m	A4(d17x0.27t)	(V/m)	
20	140-000-87	Hex.Bolt	4	M10x35(B=14)	SUS304	
21	142-128-24	Plain Washer	4	M10	SPC	
22	032-000-92	Hose Coupling (for USA)	1	KTZ33.7-63(NPT-3,Angle)	FC	
23	121-001-48	Packing	1	KTZ-3.7/7.5(Angle)	NBR	*
24	140-079-10	Hex.Bolt	4	M10x40	SUS304	
25	142-164-19	Spring Washer	4	M10	SUS304	
26	070-117-11	L-Shape Fitting	1	40x25x4.5t d13Hole	SPC	
27	050-001-10	Motor Bracket	1		FC	
28	140-288-14	Hex.Socket Cap Bolt	1	M10x35	SUS304	
29	142-164-19	Spring Washer	1	M10	SUS304	
30	122-000-09	O-Ring	1	195xd3.8	NBR	*
31	053-198-13	Motor Protector 208/230V-60Hz(USA)	1	KA314-HLZL00	(B.C)	
	053-506-18	Motor Protector 460V-60Hz(USA)	1	KA314-HMXL00	(B.C)	
	053-404-15	Motor Protector 575V-60Hz(USA)	1	KA314-HRVL201	(B.C)	
32	143-126-12	Pan Screw (w/Spring Washer/Plain Washer)	2	M4x12	SWRM	
33	009-294-13	Earth Terminal	1Set	3.5mm2x170L		
34	143-085-34	Pan Screw (w/Spring Washer)	1	M4x6	C3604	
35	142-197-11	Wave Washer	1	6305	SK5	
36	052-108-13	Bearing	1	6305ZZC3		

PARTS LIST		HI HEAD DEWATERING PUMP				6/7/2018
ITEM	PART No.	DESCRIPTION	QTY	SIZE	MATERIAL	NOTES
37	122-244-12	O-Ring	1	61.4xd3.1	NBR	*
38	058-000-35	Lead Wire Protection Plate	1	d84xd199.5x1.6t	PE	
39	055-002-59	Rotor	1Set			
40	147-026-13	Impeller Key	1	5x5x25L	SUS420	
41	056-007-24	Stator 208/230V-60Hz(USA)	1Set			
	056-007-29	Stator 460V-60Hz(USA)	1Set			
	056-007-31	Stator 575V-60Hz(USA)	1Set			
42	121-000-14	Packing (Water Way, Upp.)	1	KTZ35.5/67.5-51/61	NBR	*
43	064-000-02	Motor Frame	1		FC	
44	140-078-19	Hex.Bolt	4	M10x35	SUS304	
45	142-164-19	Spring Washer	4	M10	SUS304	
46	121-247-12	Packing	1	d12.3xd18x2t	PE	*
47	140-000-17	Hex.Bolt (w/Flange)	1	M12x15(Oil Plug)	SUS304	
48	140-000-23	Hex.Bolt (w/Spring Washer)	4	M5x10	SWRM	
49	062-000-02	Bearing Cover	4	d5.5xd18x2t	SPC	
50	052-111-19	Bearing	1	6308ZC3		
51	122-135-19	O-Ring	1	G-120(119.4xd3.1)	NBR	*
52	060-001-38	Bearing Housing	1		FC	
53	142-163-34	Spring Washer	4	M8	SWRH	
54	140-054-48	Hex.Bolt	4	M8x20	SWRM	
55	025-001-00	Mechanical Seal	1	H-25T (RoHS)	SiC	supercedes 025-000-07
56	143-070-23	Pan Screw	2	M5x6	SWRM	
57	030-143-12	Oil Lifter	1	H-25(A)(T)	Resin	
58	143-070-10	Pan Screw	4	M5x6	SWRM	
59	030-148-17	Seal Stopper	1	HT-2530	SPCC	
60	122-283-13	O-Ring	1	165xd3.1	NBR	*
61	121-124-12	Packing (Water Way, Low.)	1	KTV-37/55	NBR	*
62	020-001-04	Pump Casing	1	KTZ35.5/45.5	FC	
63	026-144-49	Oil Seal	1	TC-40588	NBR	
64	040-106-27	Impeller Shim		d20.2xd30x0.3t	SUS304	
65	021-009-07	Impeller (60Hz)	1	KTZ35.5-63	HiCrFC	
	021-009-10	Impeller (50Hz) OPTION	1	KTZ35.5-53	HiCrFC	50Hz OPTION
66	047-104-26	Impeller Thread Protect.Cover	1	No.3B(18)	SUS304	
67	142-166-11	Spring Washer	1	M16	SUS304	
68	141-033-15	Hex.Cap Nut	1	M16	SUS304	
69	120-109-21	Packing (S.Cover)		d180xd222x0.5t(d12)	PE	
70	022-000-55	Suction Cover	1	KTZ33.7/35.5	FCD	
71	142-128-24	Plain Washer	3	M10	SPC	

PARTS LIST		HI HEAD DEWATERING PUMP				6/7/2018
ITEM	PART No.	DESCRIPTION	QTY	SIZE	MATERIAL	NOTES
72	140-074-15	Hex.Bolt	3	M10x20	SUS304	
73	142-128-24	Plain Washer	3	M10	SPC	
74	144-000-31	Stud Bolt	3	M10x94(20/14)	SUS410	
75	023-471-10	Strainer Stand	1	KTZ23.7/45.5	SPCC	
76	142-128-24	Plain Washer	3	M10	SPC	
77	141-006-77	Hex.Nut	3	M10	S45C	
	173-003-41	Packing O-Ring Set	1Set	(Marked by *)		
12	122-121-12	O-Ring (S.Box)	1	G-50(49.4xd3.1)	NBR	*
23	121-001-48	Packing (Hose Coupling)	1	KTZ-3.7/7.5(Angle)	NBR	*
30	122-000-09	O-Ring (M.Bracket/M.Frame)	1	195xd3.8	NBR	*
37	122-244-12	O-Ring (Upp. Bearing)	1	61.4xd3.1	NBR	*
42	121-000-14	Packing (Water Way, Upp.)	1	KTZ35.5/67.5-51/61	NBR	*
46	121-247-12	Packing (Oil Plug)	1	d12.3xd18x2t	PE	*
51	122-135-19	O-Ring (M.Frame/Brg.Housing)	1	G-120(119.4xd3.1)	NBR	*
60	122-283-13	O-Ring (M.Frame/P.Casing)	1	165xd3.1	NBR	*
61	121-124-12	Packing (Water Way, Low.)	1	KTV-37/55	NBR	*
		Lubricant		Turbine Oil VG32 1,100ml		
	183-008-11	Impeller Puller	1	A No.3 1"	FC	

PARTS LIST		HI HEAD DEWATERING PUMP					6/7/2018
ITEM	PART No.	DESCRIPTION	QTY	SIZE	MATERIAL		NOTES

EXPLODED VIEW

